



Solenoid Valves

Installation and Servicing Instructions

SPORLAN



Solenoid Valves

Installation and Servicing Instructions

Not For Use On Hazardous or Corrosive Fluids

- The molded MKC-1 coil fits the E2, A3, E3, W3, S4, E5, B6, E6, S6, W6, S7, E8, E10S1, E35, E43, R183, R184 and R246 series normally closed solenoid valves.
- The OMKC-1 coil fits the OE6, OE8, OE10S1, OE35 and OE43 series and the XWG, XUP and XXF series rapid cycle solenoid valves.
- The MKC-2 coil fits the B9, E9, B10, E10S2, B14, E14, W14, B19, E19, W19, B25, E25, W25, B33*, E33*, E34*, E42* series normally closed solenoid valves and the 180 solenoid pilot control...and all solenoid valves in the field that are equipped with the old style KC-2 coil.
- When changing from the old KC model coils to the current MKC

molded model coils, discard the coil housing, coil housing bottom plate, two coil sleeves (not used with KC-1 coil) AND THE SPACER.

- The OMKC-2 coil fits the OB9, OE9, OB10, OE10S2, OB14, OE14, OB19, OE19, OB25, OE25, OB33*, OE33*, OE34*, OE42* series normally open solenoid valves and the XRN, XRM, XPO series rapid cycle solenoid valves.
- Other Sporlan products using a molded coil are as follows:
MKC-1 – (S)B5D, (S)8D, (S)12D, (S)16D, 10G, SORIT, SORIT-PI, SHGB(E)-8 and OLDR-16.
OMKC-1 – LDR-16
MKC-2 – DDR-20, SHGB(E)-15, OLDR-15 and OLDR-20.
OMKC-2 – LDR-15, LDR-20, XTM and XTO.

GENERAL

To ensure peak performance, solenoid valves must be selected and applied correctly; however, proper installation procedures are equally important. The following instructions list the essential points for correct installation.

An exploded view of a typical solenoid valve is illustrated on page 4 in Figures 5 and 5A.

Position – All standard solenoid valves may be mounted horizontal, on its side or in a vertical line with the exception of the following: B33*, OB33*, XWG, XXF, XUP, XRN, XRM and XPO series. These valves **MUST** be installed in horizontal lines with the coil housing no more than 45° from vertical, see table on page 3. The direction of flow is indicated by an **arrow** or the word **IN** on the inlet of the valve body. For heat pump applications, valve types C(M)E and C(M)B are typically installed with the directional arrow pointing toward the outdoor coil. Or, the **IN** connection toward the indoor coil.

NOTE: Solenoid valves having a type number starting with the letter “X” are Special Solenoid Valves (non-standard). Contact Sporlan if valve mounting is in question.

SOLDER CONNECTIONS

Because of possible damage to valve components due to the high temperatures of soldering and brazing, “B” Series Solenoid Valves with brass connections are shipped handtight to facilitate disassembly. It is necessary to completely disassemble these valves before any heat is applied to the valve body. The following steps outline recommended procedures when installing these valves.

Soldering Precautions – Solder connections on Sporlan Solenoid Valves are either copper or brass. Any of the commonly used types of solder are satisfactory with these materials. Regardless of the type of solder used, it is important to avoid overheating the valve.

The tip of the soldering torch should be large enough to avoid prolonged heating of the connection during the soldering operation. Overheating can also be minimized by directing the flame away from the valve body.

TYPE A3S1, S4S1, S6S1, S7S1

1. Remove the coil assembly.
2. Locate the word **IN** or the directional **arrow** on the valve body.
3. Place the valve in the line, in the proper direction of flow and solder.
4. Replace the coil assembly and tighten coil hex screw.

TYPES B6, B9, B10, B14, B19, B25 SERIES (Brass Connections)

1. Remove the coil assembly, enclosing tube and nut, all internal parts and manual lift stem assembly.
2. Locate the word **IN** or the directional **arrow** on the valve body.
3. Place the valve in the line in the proper direction of flow and solder.
4. Re-assemble as follows, see Figures 1, 5 and 5A:

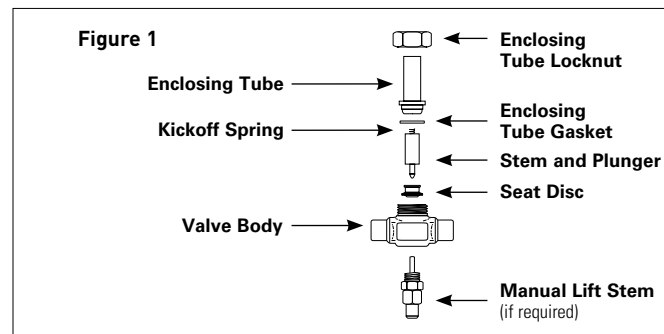

- a. Place the seat disc into the valve body with the smaller diameter end facing up.
- b. Place the enclosing tube gasket onto the valve body above the threads.
- c. Hold the plunger with one hand so that the pointed end is resting in the pilot port of the disk. Make sure the small spring is in place on the top of the plunger. (**NOTE: Does not apply to normally open and rapid cycle series.**)
- d. With the other hand, place the enclosing tube over the plunger, making sure the enclosing tube gasket is in position.
- e. Replace the enclosing tube locknut and tighten. (See recommended torque in the table on page 3.) Do not over tighten.
- f. Replace manual lift stem. Tighten lift stem assembly and seal cap.
- g. Replace the coil assembly. (**NOTE: For normally open and rapid cycle valves replace spacer and spacer cup with coil assembly.**)

NOTE: Excessive tightening of the enclosing tube locknut can damage the valve body bore. Please observe the torques listed on page 3.

TYPES: ALL E SERIES (Extended Copper Connections)

Brazed into the line without disassembly because the valve contains extended connections. Use caution by placing a wet cloth or chill block on the extensions at the body to prevent excessive overheating. Follow Type A3S1 installation instructions.

* E34, B33, E33 and E42 are obsolete. * OE34, OB33, OE33 and OE42 are obsolete.

RECOMMENDED TORQUE (ft.-lbs.)

VALVE SERIES ¹	ENCLOSING TUBE LOCKNUT ⁴	ENCLOSING TUBE SCREWS	PILOT VALVE ASSEMBLY LOCKNUT	LOWER BODY LOCKNUT	COIL SCREW	COIL LOCKNUT	FLANGE PLATE BOLTS/SCREWS	FLANGE CONNECTION ASSEMBLY	MANUAL LIFT STEM ASSEMBLY	SEAL CAP	VALVE MOUNTING POSITION		
											VERTICAL LINE ²	HORIZONTAL LINE	ON SIDE ³
A3, S4, S6, S7	—	—	—	—	2.3	—	—	—	—	—	YES dated 7-86 or later	YES	
E2, E3, E5	—	—	—	—	2.3	—	—	—	—	—	YES	YES	
W3		1.5 – 1.67									NO	YES ²	
B6, E6, W6, E8	10 – 15	—	—	—	2.3	4.0	—	—	11 – 12	4 – 6	YES	YES	
XXF, XUP		—									NO	YES ²	
B9, E9, OB9, OE9	25 – 30	—	—	—	2.3	4.0	—	—	11 – 12	4 – 6	YES	YES	
XRN		—									NO	YES ²	
E10S2	20 – 25	—	—	—	2.3	4.0	—	—	11 – 12	4 – 6	YES	YES	
B10, E10S1, OB10, OE10S1, OE10S2		—									NO	YES ²	
B14, E14, W14, OB14, OE14		—									NO	YES ²	
XRM		—									NO	YES ²	
B19, E19, W19, OB19, OE19	40 – 45	—	—	—	2.3	4.0	—	—	11 – 12	4 – 6	YES	YES	
XPO		—									NO	YES ²	
B25, E25, W25	60 – 65	—	—	—	2.3	4.0	—	—	11 – 12	4 – 6	YES	YES	
OB25, OE25		—									NO	YES ²	
B33	25 – 30	—	—	—	2.3	4.0	8 – 12	37	11 – 12	4 – 6	NO	YES ²	
OB33		—									NO	YES ²	
E35, OE35	10 – 15	—	—	—	—	—	8 – 9	—	—	—	YES	YES	
E43	10-15	—	—	—	2.3	4.0	19 – 20	—	11 – 12	4 – 6	YES	YES	
E42, OE42	25 – 30	—	—	—	2.3	4.0	13 – 20	—	11 – 12	10 – 15	YES	YES	
R183, R184, R246	—	6	—	—	2.3	—	—	—	—	—	YES	YES	
8D	10 – 15	—	60 – 65	60 – 65	2.3	—	—	—	—	—	YES	NO	
12D		—		15 – 18									
16D		—		20 – 24									
10G		—		—									

¹Valves with mounting holes use a #8-32 screw torqued not more than 15 in.-lb. **Note:** Standard torque charts do not apply. ²Coil housing to be no more than 45° from the vertical. ³Coil housing must not be below horizontal. ⁴Do not over tighten the enclosing tube locknut. Damage to the enclosing tube assembly could result from over tightening.

Note: For installation and service instructions on Three-Way Heat Reclaim Valves Type 8D, 12D & 16D, request Form SD-114.

PIPE CONNECTIONS

Types A3, W3, B6, W6, B9, B10, B14, W14, B19, W19, B25, W25, (K)(B)R183, (K)(B)R184, (K)(B)R246 Series

These valves can be installed without disassembly. Avoid excessive amounts of pipe sealing compounds. It will interfere with the valve operation if it comes in contact with the valve's internal parts.

NOTE: When pipe type solenoid valves are installed with pipe to ODF adaptors, the valve must be disassembled prior to brazing the ODF adaptors.

FLANGED CONNECTIONS – PIPE or SOLDER

Solenoid valves with flanged connections may be installed without disassembly. In most cases the flanges are packed disassembled from the valve body. Therefore, they may be installed in the line before the valve is installed. Be certain that the correct flange is installed on the inlet line in order to properly match the flow direction of the valve. If the valve is installed backwards, it will not function properly.

Types B33S2, MB33S2, OB33S2 (Obsolete)

These valves are supplied with a two piece flange assembly, a semi-steel flange ring and a brass solder bushing. The flange should be placed on the pipe before the bushing is soldered or brazed. The soldering discussion given under "Solder Connections" applies for these valves except where the discussion deals with non-flanged valves only.

INSTALLATION—ALL VALVES

Mounting – A Type 1216-1 universal mounting bracket, Figure 2, is available, when ordered. It fits all standard Sporlan Solenoid Valves except the Types W3, B33, E33, E35, E42, E43, (K)(B)R183, (K)(B)R184, (K)(B)R246 series and the Type 180 Solenoid Pilot Control. The slots in the bracket match the tapped holes in the standard solenoid valves so that they may be secured by two screws supplied with the bracket.

Figure 2

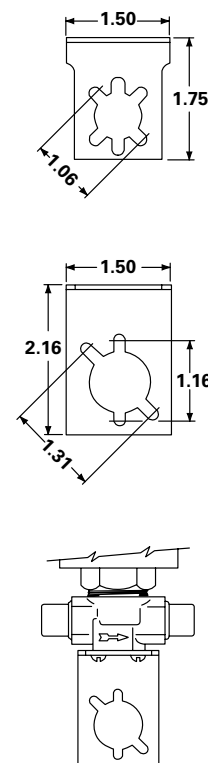

Installation for Types A3, E3*, E5*, B6, E6*, W6, E8*, B9, E9*, B10, E10S1*, E10S2, B14, E14, W14, B19, E19, W19, B25, E25, W25, Series Solenoid Valves.

*Are not supplied standard with mounting holes.

Wiring – Check the electrical specifications of the coil to be sure they correspond to the available electrical service.

The 1/2" BX conduit connection or junction box on the coil may be rotated to any position by loosening the coil hexscrew. Solenoid valves with four-wire dual voltage coils have a wiring diagram decal, Figure 3, on the coil housing or bracket. This illustrates which wires to connect for either 120, 208 or 240 volt operation. Wiring and fusing (when used) must comply with prevailing local and national wiring codes and ordinances.

Figure 3

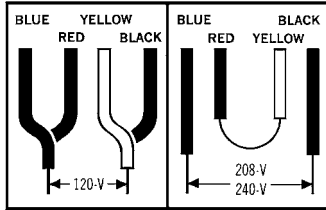

Direct Current Valves – A surge protector is recommended with each solenoid valve with a 115 volt DC coil. The surge protector is necessary to absorb the high counter-voltage generated when the circuit is broken, thereby protecting the electrical contacts of the thermostat. It should be wired as shown in Figure 4.

Figure 4

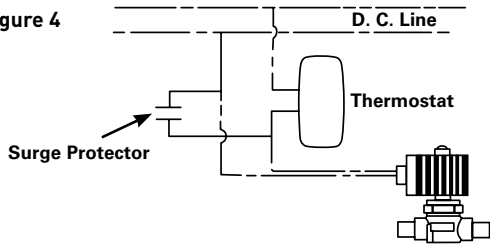

TRANSFORMER SELECTION

COIL KIT	24v/50-60c		120v/50-60c		240v/50-60c		Transformer Rating Volt-Amperes
	Current Amperes		Current Amperes		Current Amperes		
	In-rush	Hold-ing	In-rush	Hold-ing	In-rush	Hold-ing	For 100% of rated MOPD of Valve
MKC-1	1.9	.63	.39	.14	.19	.09	60
OMKC-1	1.9	.94	.42	.21	.20	.10	60
MKC-2 OMKC-2	3.1	1.4	.60	.26	.31	.13	100

SERVICING INSTRUCTIONS

CAUTION – Dangerous hydraulic pressures may develop if a hand valve is installed in the liquid line ahead of the solenoid valve and the hand valve is closed while the solenoid valve is closed. This may cause extrusion of the teflon seat in the disc. Extrusion may cause the valve to fail to open, fail to close and/or have excessive seat leakage. Also the line between these two valves should be pumped down completely before disassembling the solenoid valve for service.

NOTE: The optional manual lift stem is designed to prevent damage to the disc. If the stem is turned in too far, the threads become disengaged. These threads can be re-engaged by applying slight outward force while turning counterclockwise. A thread stop is provided to prevent the stem from backing all the way out of the assembly. Back the stem to the stop and replace the seal cap when service is complete.

TYPICAL MALFUNCTIONS

There are only three possible malfunctions: coil burnout, failure to open and failure to close. Each is discussed.

COIL BURNOUT

Coil burnouts are extremely rare unless caused by one of the following:

1. Improper electrical characteristics.
2. Continuous over-voltage, more than 10%.
3. Under-voltage of more than 15%. This applies only if the operating conditions are such that the reduced MOPD causes stalling of the plunger, which results in excessive current draw.
4. Incomplete magnetic circuit due to the omission of parts such as: coil housing, coil sleeves, coil spring, coil housing bottom plate or plunger on the KC model coil and coil yoke, coil backplate or plunger on the MKC molded model coils.
5. Mechanical interference with plunger movement which may be caused by a deformed enclosing tube.
6. Voltage spike.
7. Valve ambient exceeds 120°F.
8. Fluid or gas temperatures greater than 240°F, while the valve ambient is 120°F.

FAILURE TO OPEN (Normally Closed Types)

1. Coil burned out or an open circuit to coil connections.
2. Improper electrical characteristics.
3. In pilot operated valves, dirt, scale or sludge may prevent the piston, disc or diaphragm from lifting. This could also be caused by a deformed body.
4. High differential pressure that exceeds the MOPD rating of the valve.
5. Diameter reduction of synthetic seating material in pilot port because of high temperatures and/or pressures, or severe pulsations. Contact Sporlan Division, Washington, MO.

The problem of dirt can be avoided by installing a Sporlan Catch-All® Filter-Drier upstream from the solenoid valve. The Catch-All® Filter-Drier will retain much smaller particles than a conventional strainer.

Use a Sporlan strainer for water applications upstream of every industrial solenoid valve.

FAILURE TO CLOSE

1. Valve is oversized. Pilot operated valves may fail to close due to low pressure drop.
2. In pilot operated valves, dirt, scale or sludge may prevent the piston, disc or diaphragm from closing. This could also be caused by a deformed body.
3. Held open by the manual lift stem.
4. In pilot operated valves only, a damaged pilot port may prevent closing.
5. A floating disc due to severe discharge pulses, contact Sporlan Valve, Washington, MO.
6. Have voltage feedback to the coil after the coil de-energizes.

MISCELLANEOUS

Liquid Hammer – Industrial solenoid valves, or other liquid line valves, may cause liquid hammer when installed on liquid lines with high liquid velocities. If this occurs, it can be minimized by the use of larger pipes, (i.e. lower velocities), or a standpipe installed in the piping near the solenoid valve inlet. Commercially available shock absorbers may also be used to reduce this noise. Recommended maximum velocity is approximately 300 fpm.

AC Hum – This problem may be caused by a loose coil. A loose coil hex screw or coil locknut may cause this problem on the MKC molded model coils.

Foreign material between the magnetic top plug and the plunger in the Types A3, E3, W3, E5, B6, E6, W6, E8, B9, E9, B10S2, E10S1, E10S2, B14, E14, W14, B19, E19, W19, B25, E25, W25, E35 and E43 Series Solenoid valves may cause AC hum also.

On water applications, deposits may accumulate in the valve which could cause AC hum. This may be eliminated by cleaning or flushing the valve.

Leak Testing – Special care should be taken when leak testing valves with synthetic gaskets. Gasket materials typically have a miniscule permeability. Leak rates of 0.5 oz. per year, depending on the valve size, is acceptable in most cases. Note the sensitivity of electronic leak detectors. Most have the capability of finding a leak smaller than 0.05 oz. per year. Double check small seal leaks with soap bubbles or a halide torch if possible.

If a leak occurs, change the gasket and verify the metal surfaces have a clean smooth finish.

Figure 5

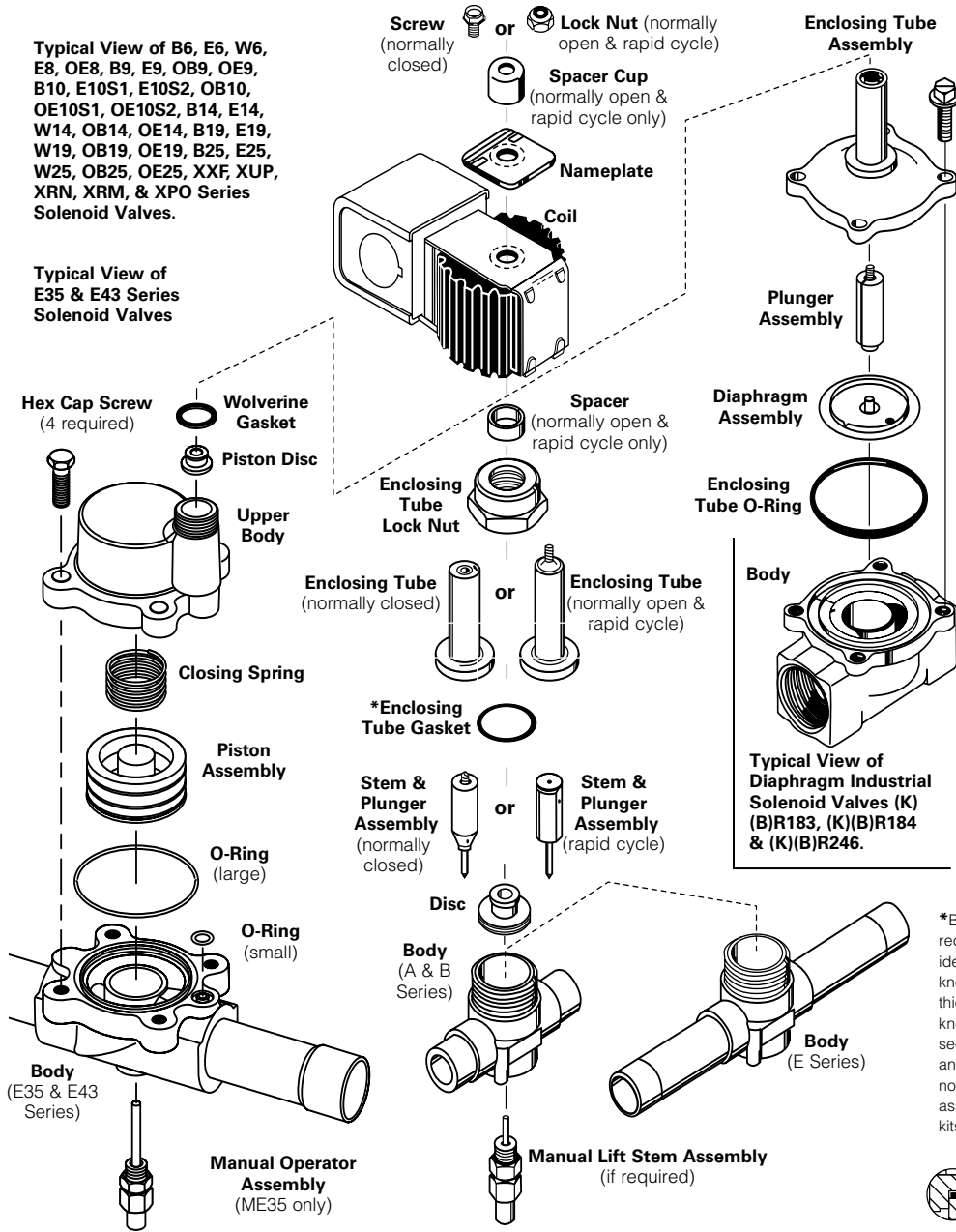
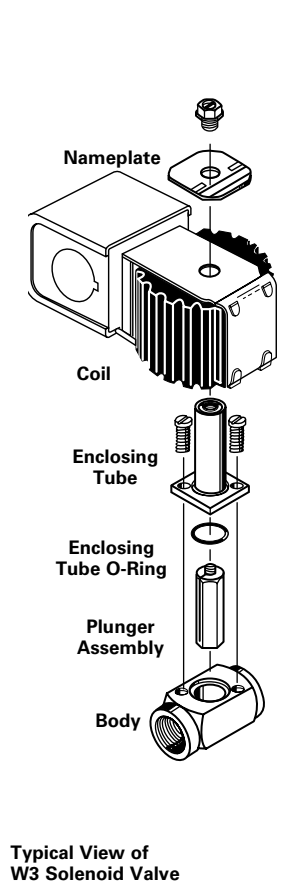
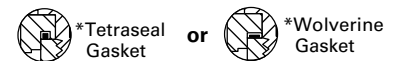

Figure 5A



*B and E Series Solenoid Valves have been redesigned. The new design can be easily identified as a thin, synthetic coated metal gasket, known as a Wolverine gasket. The old gasket is a thicker type of O-ring with a square cross section, known as a tetraseal. See the partial cross sections of the valve body below. The gaskets and the enclosing tubes of the two designs are not interchangeable. The new enclosing tube assembly is included in the replacement parts kits.



INSTALLATION PRECAUTIONS

1. Do not attempt to disassemble the valve before pumping the system down. Make absolutely certain the pressure in the lines is no more than 2 or 3 psi above atmospheric pressure before removing any valve parts (except coil assembly).
2. The solenoid coil must not be energized unless it is installed on the valve. To do so would cause coil to overheat and burn out.
3. The solenoid coil should be fused in accordance with local codes.
4. If additional brazing is required after the system has been charged, additional precautions are necessary. Pump the entire system down and purge the section where brazing is to be done. Do not use a solenoid valve as a safety shut off while making repairs to a system. After reducing the pressure to atmospheric, the valve may be opened and internal parts removed. **The area should be vented thoroughly to prevent formation of dangerous fumes which could result from the refrigerant in the presence of an open flame.**
5. Make sure the line and/or valve body is cooled sufficiently before reassembly to avoid damage to synthetic materials.
6. If a hand valve is installed ahead of a solenoid valve, it should be closed only to service the system. The hand valve should be opened as soon as the service is complete. If the solenoid valve were closed and the hand valve remains closed, trapping liquid between the two, dangerous hydrostatic pressures could result causing bodily injury.
7. Do not twist the valve assembly by pulling or pushing on the enclosing tube or coil assembly.
8. Do not carry a coil assembly or complete valve by the coil leads. This could damage the coil and cause a coil burnout.
9. Pipe type solenoid valves should be disassembled prior to installation if pipe to sweat adapters are to be used for installation.
10. Electrically ground the valve body. Typically this is done through the fluid piping or the electrical conduit.
11. Before energizing the valve, verify that the supply voltage and frequency matches the solenoid coil marking.

COILS and INTERNAL PARTS KITS for CURRENT and OBSOLETE VALVE TYPES

VALVE SERIES	REPLACEMENT COIL KIT NUMBER	INTERNAL PARTS KIT NUMBER	
10	MKC-2	None	
E2, A3, E3	MKC-1		
E5			
A6			
B6, MB6, E6, ME6			
E8, ME8			
E10S1, ME10S1			
E35, ME35			
E43, ME43			
OE6-HP			OMKC-1
OE8-HP		KS-OE6-HP/OE8-HP	
OE10S1-HP	KS-OE10S1-HP		
OE35	KS-OE35-HP		
OE43	KS-OE43-HP		
14	MKC-2	None	
A9		KS-B9/E9	
B9, MB9, E9, ME9		OMKC-2	KS-OB9/OE9
OB9, OE9	No longer available		
A10, MA10	MKC-2	KS-B10/E10	
B10, MB10, E10S2, ME10S2	OMKC-2	KS-OB10/OE10	
OB10, OE10S2		No longer available	
20	KC-12	No longer available	
73		No longer available	
A14, MA14	MKC-2	No longer available	
B14, MB14, E14, ME14		KS-B14/E14	
OB14, OE14		KS-OB14/OE14	
43	MKC-3	No longer available	
A17, MA17		No longer available	
B19, MB19, E19, ME19	MKC-2	KS-B19/E19	
OB19, OE19	OMKC-2	KS-OB19/OE19	
53	MKC-3	No longer available	
A24, MA24		No longer available	
B25, MB25, E25, ME25		KS-B25/E25	
OB25, OE25	OMKC-2	KS-OB25/OE25	
90, 9001, 9005	MKC-3	No longer available	
MA32, B32, MB32		No longer available	
C32, MC32		MKC-2	KS-B33/E33
B33, MB33, E33, ME33			KS-E34
EB33, EMB33	OMKC-2	KS-OE34	
E34, ME34		KS-OB33/OE33	
OE34		MKC-3	No longer available
OB33, EOB33, OE33	KS-E42		
100	OMKC-2		KS-OE42
MA42, EMB42	MKC-3	No longer available	
E42, ME42		No longer available	
OE42		No longer available	
110		No longer available	
MA50	MKC-3	No longer available	
35		No longer available	
MA5A3		No longer available	
83		No longer available	
MA17A3		W3P1	
W3	MKC-1	W6P1	
W6		No longer available	
W7	MKC-2	KS-W14	
W14		KS-W19	
W19		KS-W25	
W25		MKC-1	KS-R18
(K)R183	KS-R24		
(K)R184	KS-BR18		
(K)R246	KS-BR24		
(K)BR183	OMKC-1		None
(K)BR184			KS-XXF
(K)BR246		KS-XUP	
XWG	OMKC-2	KS-XRN	
XXF		KS-XRM	
XUP		KS-XPO	
XRN			
XRM			
XPO			

NOTE: The KC-43 coil kit and KC-3 coil kit have been renumbered and is now designated as the MKC-3. The two coils are identical.

*KS-B6 kits may be used in A6 series valves, but KS-A6 kits should not be used in B6 series valves.

When servicing the B-HP or E-HP series solenoid valves, it is important to assemble the springs and spring guide into the plunger correctly. See below.

For valves with a kickoff spring and return spring, place kickoff spring into top of plunger, then place return spring into kickoff spring. Place this assembly into the enclosing tube. Be sure the return spring moves into the dimple in the top plug. Do so, by holding the enclosing tube vertical with the top plug pointing up. Then, slide the plunger assembly into the enclosing tube. After assembly, press the stem of the plunger assembly several times until one feels the spring slip into the dimple. Carefully, assemble onto valve body.

Figure 6

**E-HP Series
B6, E6, E8, E10S1,
E35, E43**

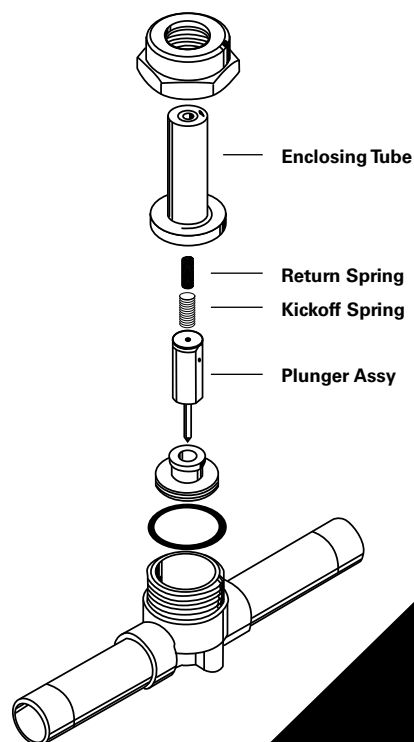

For valves with a kickoff spring, return spring, and spring guide, place kickoff spring into top of plunger, place return spring into kickoff spring, then place spring guide into return spring. Place this assembly into the enclosing tube. Be sure the spring guide moves into the dimple in the top plug. Do so, by holding the enclosing tube vertical with the top plug pointing up. Then, slide the plunger assembly into the enclosing tube. After assembly, press the stem of the plunger assembly several times until one feels the spring guide slip into the dimple. Carefully, assemble onto valve body.

Figure 7

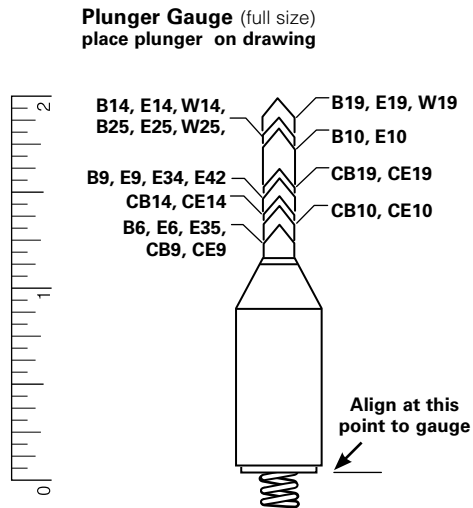

Listed by Underwriters' Laboratories, Inc.
Guide-Y10Z File No. MH4576

Manual Lift Stem Gauge
(full size)
place stem on drawing

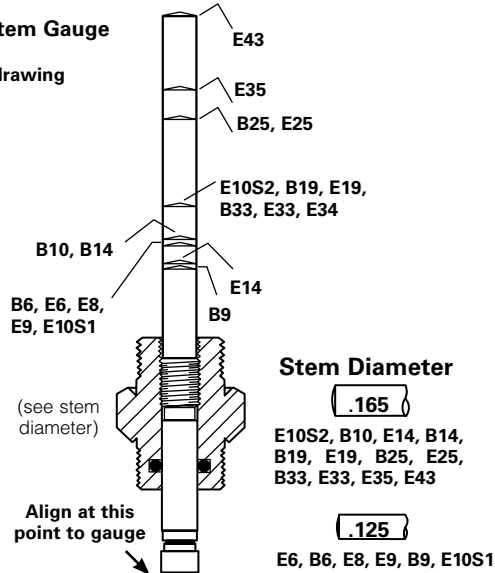

Listed by Canadian Standards Association
Guide-440-A-O File No. 19953

GENERAL PURPOSE SOLENOID VALVES

BASIC VALVE TYPE	AMBIENT TEMP. RATING (°F)	*FLUID TEMP. RATING (°F)	APPROVED FLUIDS
A3, E2, E3	120	240	1
E5	120	240	1
B6, E6	120	240	1
E8	120	240	1
B9, E9	120	240	1
E10S1	120	240	1
B10, E10S2	120	240	1
B14, E14	120	240	1
B19, E19	120	240	1
B25, E25	120	240	1
E35	120	240	1
E42	120	240	1
E43	120	240	1
R18	120	240	4
R24	120	240	4
W3, RW3	120	240	4
W6	120	240	4

BASIC VALVE TYPE	AMBIENT TEMP. RATING (°F)	*FLUID TEMP. RATING (°F)	APPROVED FLUIDS
W14	120	240	4
W19	120	240	4
W25	120	240	4
SHGB-15	120	240	1
SORIT-12, 15, 20	120	240	1
8D	120	240	1
12D	120	240	1
16D	120	240	1
10G	120	240	1
180	120	240	1
XWG	120	240	1
XXF	120	240	1
XUP	120	240	1
XRN	120	240	1
XRM	120	240	1
XPO	120	240	1

APPROVED FLUIDS —
1 — All Halogenated Refrigerants, 4 — Dry Air, Water and Steam, * Minimum fluid or gas temperature is -40°F, † Minimum ambient temperature is -40°F

⚠ WARNING - USER RESPONSIBILITY

Failure or improper selection or improper use of the products described herein or related items can cause death, personal injury and property damage. This document and other information from Parker Hannifin Corporation, its subsidiaries and authorized distributors provide product or system options for further investigation by users having technical expertise.

The user, through its own analysis and testing, is solely responsible for making the final selection of the system and components and assuring that all performance, endurance, maintenance, safety and warning requirements of the application are met. The user must analyze all aspects of the application, follow applicable industry standards, and follow the information concerning the product in the current product catalog and in any other materials provided from Parker or its subsidiaries or authorized distributors.

To the extent that Parker or its subsidiaries or authorized distributors provide component or system options based upon data or specifications provided by the user, the user is responsible for determining that such data and specifications are suitable and sufficient for all applications and reasonably foreseeable uses of the components or systems.

OFFER OF SALE

The items described in this document are hereby offered for sale by Parker Hannifin Corporation, its subsidiaries or its authorized distributors. This offer and its acceptance are governed by the provisions stated in the detailed "Offer of Sale" available at www.parker.com. For safety information see the Safety Guide at www.parker.com/safety or call 1-800-CParker.

FOR USE ON REFRIGERATION and/or AIR CONDITIONING SYSTEMS ONLY

Bulletin 30-11, November 2015 supersedes Bulletin 30-11, March 2009 and all prior publications.



Parker Hannifin Corporation
Sporlan Division
206 Lange Drive • Washington, MO 63090 USA
phone 636 239 1111 • fax 636 239 9130, www.sporlan.com